

LED MODULE - ASTECHM902TB -0.72W



- FIVE YEAR WARRANTY*
- 2835 SMD LED, long life, low attenuation
- Over-moulded Design with IP65 protection
- Superior Luminous Flux - 70lm/module (white), 13lm/module (red)
- Large Viewing Angle (160 degrees)
- CE, UL, RoHS approved
- 22,000 Hours* +
- Suitable for Channel Lettering, Light Boxes and Backlighting
- Optimum depth 60mm - 180mm
- Available in Neutral White, Red
- 50 module string

Please See Over for Full Tech Spec

*Note: Warranty is 5 years or 22,000 hours which ever comes first

ASTECH (a Division of the Albert Smith Group)

59 Taylor St Bulimba Qld 4171, Ph. 07 3395 9888 FX.07 38910713

EMAIL: enquiries@asgroup.com.au WEB: www.albertsmithgroup.com.au

ABN. 42345973910

Product Specifications

	Model No.	Model No.	M903TB
Physical	Color		Neutral White/ Red
	Dimensions (length x width x height)		1.77" x 0.51" x 0.37"
	Color Temperature		6000K (white)/ 620~625 (red)
	LED Chips / Module		2
	LED Modules / Foot		2
	LED Modules / String		50
	Operating Temperature		-25 ~ 60 °C (-13 ~ 140 °F) white/red
	Storage Temperature		-25 ~ 70 °C (-13 ~ 158 °F) white/red
	View Angle		160°
Electrical	Power Consumption		0.72 W
	Forward Voltage		12V
	Forward Current		60 mA

Product Dimensions

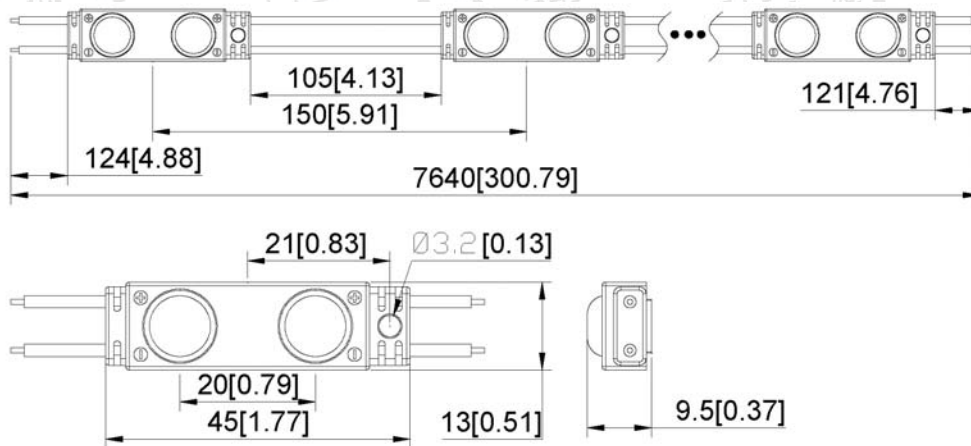

Units: mm [in]

Light Distribution

